



WWW.C4MECCANICA.IT

ACCESSOIRES POUR
Les Engins de Terrassement

C4 MECCANIC
Zone Ind.le Madonna del Moro - 06019
Umbertide (PG)

SOMMAIRE

- BROYEURS HYDRAULIQUES

- SÉRIE A
- SÉRIE B
- SÉRIE C
- SÉRIE D

- BROYEURS HYDRAULIQUES FORESTIERS

- SÉRIE FL
- SÉRIE F
- SÉRIE FF

- BROYEURS POUR CHARGEURS COMPACTS

- SÉRIE DML
- SÉRIE DM
- SÉRIE DMM

- TARRIERE POUR MACHINE DE TERRASSEMENT

- GODET MALAXEUR

- GODET ORIENTABLE

- GRAPPIN

- Pincés

BROYEUR HYDRAULIQUE POUR MINI-PELLE DE 1.5 à 5 T.



Modèle. A

COMPLET AVEC :

- Support auto-nivelant
- Structure renforcée : internes et externes en Hardox
- Boîtier de PROTECTION MOTEUR : Débit/Pression/ Roue libre
- Carter de protection moteur
- Transmission directe
- Rouleau de support réglable
- Protecteurs en chaîne et caoutchouc anti-abrasion
- Flexible (1,6 m)

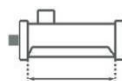
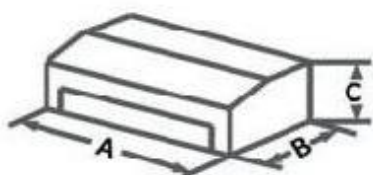

Modèle.	A	B	C	Cm	N	N	L.MIN	Bar	Kg
A60 A60	80	65	55	60	24	-	20-50	200	113
A80 A80	100	65	55	80	32	-	20-50	200	123
A100	120	65	55	100	48	16	30-80	200	180

ACCESSOIRE ET PIECE EN OPTION

RA60/80	KIT COUTEAU DE REMPLACEMENT MOD. A60 ET MOD. A80 A80
----------------	---



RA100C	KIT COUTEAU DE REMPLACEMENT POUR MOD. A100
---------------	---



RA100Z	MARTEAUX DE REMPLACEMENT POUR MOD. A100
---------------	--



MTI-A	MOTEUR HYDRAULIQUE SÉRIE A
--------------	-------------------------------



FB-AB	BLOC SECURITE MOTEUR SERIE A-B
--------------	-----------------------------------



PAR-ABC	KIT JOINTS D'ARBRE MOTEUR
----------------	---------------------------



ATS(A)	ATTACHE STANDARD DE 1,5 à 3 tonnes
	KIT D'AXES ATTACHE ATS(A)



ATS(AB)	ATTACHE STANDARD DE 3 à 6 tonnes
	KIT D'AXES ATTACHE ATS(AB)



ATA(A)	KIT SUPPORT AUTO-NIVELANT
---------------	---------------------------



BROYEUR HYDRAULIQUE MINI-PELLE DE 3 à 5 T



Modèle. B

COMPLET AVEC :

- Support auto-nivelant
- Structure avec renforts internes et externes
- Boîtier de PROTECTION MOTEUR : Débit/Pression/Roue libre
- Carter Protection Moteur
- Rouleau de support réglable
- Protecteurs en chaîne et caoutchouc anti-abrasion
- Flexible (2 m)
- Patins d'appuis avec bandes anti-usure interchangeables
- Transmission directe

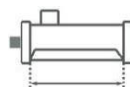

Modèle.	A	B	C	Cm	N	N	L.MIN	Bar	Kg
B80 (B80)	105	70	62	80	36	12	30-80	230	221
B100 (B100)	125	70	62	100	48	16	40-80	230	241

ACCESSOIRE ET PIECE EN OPTION

RB80-100C	KIT COUTEAU DE REMPLACEMENT POUR MOD. B80 ET B100
------------------	--



RB80-100Z	KIT DE MARTEAUX DE REMPLACEMENT MOD. B80 ET B100
------------------	---



MTI-BC	MOTEUR HYDRAULIQUE SÉRIE B-C
---------------	---------------------------------



FB-AB	BLOC SECURITE MOTEUR SERIE A-B
--------------	-----------------------------------



PAR-ABC	KIT JOINTS D'ARBRE SERIE A-B-C
----------------	-----------------------------------



ATS(AB)	ATTACHE STANDARD De 3 à 6 tonnes
	ATS(AB) KIT D'AXES



ATA (C.-B.)	SUPPORT AUTO-NIVELANT SÉRIE B-C
--------------------	------------------------------------



BROYEURS HYDRAULIQUE MINI-PELLE

DE 4 à 8 T



Modèle. C

COMPLET AVEC :

- Support auto-nivelant
- Cadre avec des renforts internes et externes
- Boitier de PROTECTION MOTEUR : Débit/Pression/ Roue libre
- Carter de Protection Moteur
- Rouleau de support réglable
- Protectors en chaîne et caoutchouc anti-abrasion
- Flexible (2 m)
- Patins d'appuis avec bandes anti-usure interchangeables
- Transmission par courroie

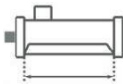

Modèle	A	B	C	Cm	N	N	L.MIN	Bar	Kg	
C90	105	75	65	90	36	12	40-80	230	310	2
C110	125	75	65	110	48	16	40-80	230	350	2

ACCESSOIRE ET PIECE EN OPTION

RC90-110C	KIT COUTEAU DE REMPLACEMENT MOD. C90 et C110
------------------	--



RC90-110Z	KIT DE MARTEAUX DE REMPLACEMENT MOD. C90 et C110
------------------	--



MTI-BC	MOTEUR HYDRAULIQUE SÉRIE B-C
---------------	------------------------------



FB-CD	BLOC SECURITE MOTEUR SÉRIE C-D
--------------	--------------------------------



PAR-ABC	KIT JOINTS D'ARBRE MOTEUR HYDRAULIQUE SERIE A-B-C
----------------	---



ATS(C)	ATTACHE STANDARD DE 4 à 8 tonnes
	KIT D'AXES ATTACHE ATS(C)



ATA (C.-B.)	SUPPORT AUTO-NIVELANT SÉRIE B-C
--------------------	---------------------------------



BROYEUR AVEC MARTEAUX CACHÉS POUR PELLE DE 6 À 15 T



Modèle. D

COMPLET AVEC :

- Cadre avec des renforts internes et externes
- Boitier de PROTECTION MOTEUR : Débit/Pression / Roue libre
- Carter de Protection Moteur
- Rouleau de support réglable
- Protectors en chaîne et caoutchouc anti-abrasion
- Flexible (3 m)
- Patins d'appuis avec bandes anti-usure interchangeableables
- Transmission par courroie

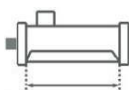
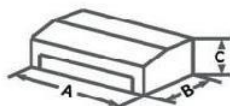

Modèle	A	B	C	Cm	N	N	L.MIN	Bar	Kg	
D110	135	80	75	110	36	12	60-90	250	450	3
D130	155	80	75	130	48	16	60-90	250	470	3
D160	185	80	75	160	48	16	80-130	250	530	3

ACCESSOIRE ET PIECE EN OPTION

RD110-130-160C	KIT COUPEAU DE REMPLACEMENT POUR MOD. D110-D130- D160
-----------------------	--



RD110-130-160Z	KIT MARTEAUX DE REMPLACEMENT POUR MOD. D110-D130- D160
-----------------------	---



MTI-D (en)	MOTEUR HYDRAULIQUE STANDARD SÉRIE D (Moteur à engrenages)
-------------------	--



MTIP-D	MOTEUR HYDRAULIQUE À PISTON SÉRIE D
---------------	--



FB-CD	BLOC SECURITE MOTEUR SÉRIE C-D
--------------	-----------------------------------



PAR-D	KIT JOINTS D'ARBRE MOTEUR HYDRAULIQUE SERIE D
--------------	--



ATS(D)	ATTACHE STANDARD DE 6 à 10 tonnes
	KIT D'AXES ATTACHE ATS(D)



ATS (D160)	ATTACHE STANDARD DE 10 à 20 tonnes
	KIT D'AXES ATS (D160)



ATA(D)	SUPPORT SÉRIE D AUTO-NIVELANT
---------------	-------------------------------



BROYEUR AVEC DES MARTEAUX FLOTTANTS POUR PELLE DE 5 A 18 T



Modèle. FL

COMPLET AVEC :

- Structure renforcée : internes et externes
- Flexible (3m)
- Patins d'appuis avec bandes anti-usure interchangeables
- Moteur hydraulique avec drainage
- Moteur hydraulique à piston (FL130-FL160)
- Carter de Protection
- Transmission à courroie

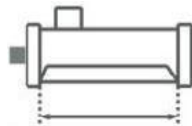
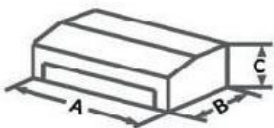

Modèle.	A	B	C	Cm	N	N	L.MIN	Bar	Kg	
FL100 (EN)	130	95	61	100	-	16	60-80	250	450	4
FL130 (EN)	169	97	65	130	-	24	60-100	250	670	4
FL160 (EN)	198	97	65	160	-	24	90-140	250	730	4

ACCESSOIRE ET PIECE EN OPTION

RFL100M	MARTEAU OUVERT POUR MOD. FL100, Nouveau 100
----------------	---



RFL100MC	MARTEAU FERMÉ POUR MOD. FL100, Nouveau100
-----------------	---



RFL100P (RFL100P)	AXES FIXATION MARTEAUX MOD. FL100, Nouveau100
------------------------------	--



RFL130M	MARTEAUX DE REMPLACEMENT POUR MOD. FL130, Nouveau130
RFL130P	AXES DE FIXATION MARTEAU MOD. FL130, Nouveau130



RFL160M	MARTEAUX DE REMPLACEMENT POUR MOD. FL160, Nouveau160
RFL160P	AXES DE FIXATION MARTEAU POUR MOD. FL160, Nouveau160



MTI-FL100	MOTEUR HYDRAULIQUE STANDARD POUR FL100
------------------	---



MTIP-F	MOTEUR A PISTON POUR SÉRIE F - MOD. FL130 - FL160
---------------	--



MTIPV-FL	MOTEUR HYDRAULIQUE À CYLINDRÉE VARIABLE
-----------------	--



Ats 1	ATTACHES 2 AXES (SÉRIE F-FF-FL) Da 6 à 10 tonnes
	KIT AXE POUR ATS1



Ats 2 ANNONCES	ATTACHE 2 AXES (SÉRIE F-FL-FF) De 10 à 20 tonnes
	KIT AXES POUR ATS2



BROYEURS MARTEAUX FLOTTANTS ROTOR CARÉNÉ POUR PELLE DE 9 A 20 T



Modèle. F

COMPLET AVEC :

- Cadre avec des renforts internes et externes
- Flexible (3 m)
- Patins d'appuis avec bandes anti-usure interchangeables
- Moteur hydraulique à piston avec drainage
- Porte réglable hydrauliquement
- Carter de Protection Moteur
- Protections en chaîne
- Transmission par courroie

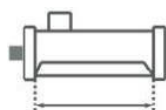

Modèle	A	B	C	Cm	N	N	L.MIN	Bar	Kg	
F100	140	95	67	100	-	20	80-130	250	605	4
F130	170	97	67	130	-	28	100-150	250	820	4

ACCESSOIRE ET PIECE EN OPTION :

RF100-130M	MARTEAU DE REMPLACEMENT POUR MOD. F100-F130
RF100P (RF100P)	ARBRE DE FIXATION MARTEAUX POUR MOD. F100
RF130P	ARBRE DE FIXATION MARTEAUX POUR MOD. F130



ATS 1 ANNONCES	ATTACHE 2 AXES (SÉRIE F-FF-FL) De 6 à 10 tonnes
	KIT D'AXES POUR ATS1



ATS 2 ANNONCES	ATTACHE 2 AXES (SÉRIE F-FL-FF) De 10 a 20 tonnes
	KIT D'AXES POUR ATS2



MTIPV-F	MOTEUR HYDRAULIQUE À CYLINDREE VARIABLE POUR F100-F130
----------------	--



BROYEURS À DENTS FIXES POUR PELLE DE 5 à 18 T



Modèle. FF

COMPLET AVEC :

- CARTER avec renforts internes et externes en Hardox
- Flexible (3 m)
- Patins d'appuis avec bandes anti-usure interchangeables
- Porte réglable hydrauliquement
- Moteur à piston avec drainage Externe
- Chaîne de protection
- Transmission par courroie
- Carter protection Moteur

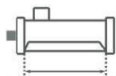

Modèl.	A	B	C	Cm	N	N	L.MIN	Bar	Kg	
FF80 (FF80)	100	95	62	70	16	-	60-80	250	390	4
FF100	130	95	62	100	20		80-100	250	450	4
FF130	158	83	87	130	26	-	100-150	250	710	4

ACCESSOIRE ET PIECE EN OPTION

RFF80-130DL	MARTEAU STANDARD POUR MOD. FF80/FF130
RFF80-130DP	MARTEAU POINTU POUR MOD. FF80/FF130
RFFB (RFFB)	VIS DE REMPLACEMENT POUR LA SÉRIE FF



ATS 1 ANNONCES	ATTACHE 2 AXES (SÉRIE F-FF-FL) Da 6 à 10 tonnes
	KIT AXES POUR ATS1



ATS 2 ANNONCES	ATTACHE 2 AXES (SÉRIE F-FL-FF) De 10 à 20 tonnes
	KIT AXES POUR ATS2



MTIPV-F	MOTEUR HYDRAULIQUE A PISTONS A CYLINDRÉE VARIABLE POUR FF130
----------------	---



BROYEUR HYDRAULIQUE POUR CHARGEUR COMPACT



Mod. DM

COMPLET AVEC :

- Carter avec des renforts internes et externes
- Attache universelle pour mini-chargeur
- Rouleau de support réglable
- Protecteurs en chaîne et caoutchouc anti-abrasion
- Déport hydraulique
- Système oscillant et auto-nivelant
- Transmission par courroie

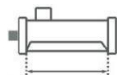
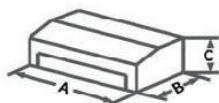

Modél.	A	B	C	Cm	N	N	L.MIN	Bar	Kg	
DM160	189	142	76	160	48	16	70-100	220	810	4
DM190	220	142	76	190	60	20	90-120	200	860	4

ACCESSOIRE ET PIECE EN OPTION

RDM160-190 C

KIT COUTEAU DE REMPLACEMENT
POUR MOD. DM160 ET DM190



RDM160-190 Z

KIT MARTEAUX DE REMPLACEMENT
POUR MOD. DM160 ET DM190



MTIP-DM

MOTEUR À PISTON



ELETT-DM

ELECTROVANNE POUR LA COMMANDE
DE TRANSLATION LATÉRALE



BROYEUR HYDRAULIQUE POUR CHARGEUR COMPACT



COMPLET AVEC :

- Cadre avec des renforts internes et externes
- Rouleau de support réglable
- Protections en caoutchouc anti-abrasion
- Patins d'appuis avec bandes anti-usure interchangeables
- Attache universelle pour chargeur compact
- Transmission par courroie

Modèle. Dml

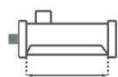
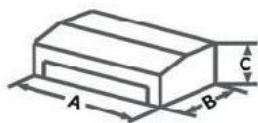

Modèle	A	B	C	Cm	N	N	L.MIN	Bar	Kg	
DML160	189	142	76	160	48	16	55-100	220	565	4
DML190	220	142	76	190	60	20	70-120	200	610	4

ACCESSOIRE ET PIECE EN OPTION

RDML160-190 C

KIT COUTEAU DE
REPLACEMENT POUR
MOD. DML160 ET DML190



RDML160-190 Z

KIT DE MARTEAUX DE
REPLACEMENT POUR MOD.
DML160 ET DML190



MTIP-DM

MOTEUR À PISTON



BROYEUR HYDRAULIQUE CHARGEUR COMPACT



Mod. DMM

COMPLET AVEC :

- Carter en Hardox avec renforts internes et externes
- Rouleau de support réglable
- Patins d'appuis avec bandes anti-usure interchangeables
- Attache universelle pour chargeur compact
- Moteur hydraulique à piston avec drainage externe
- Transmission à courroie
- Tôles antiprojections
- Déport mécanique
- Platine de fixation oscillante

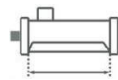
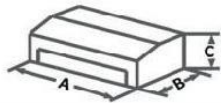

Modèle.	A	B	C	Cm	N	N	L.MIN	BAR MAX	Kg	
DMM120	135	110	68	120	36	12	40-80	200	420	3
DMM130	145	110	68	130	36	12	40-80	200	450	3
DMM140	155	110	68	140	42	14	50-100	200	470	3
DMM160	175	110	68	160	48	16	70-120	200	485	3

ACCESSOIRE ET PIECE EN OPTION

RDMMC (EN)	KIT COUTEAUX DE REMPLACEMENT POUR LA SÉRIE DMM
-------------------	---



RDMMZ (EN)	KIT MARTEAUX DE REMPLACEMENT POUR LA SÉRIE DMM
-------------------	---



SPOST-DMM	KIT DEPORT HYDRAULIQUE
------------------	------------------------

TARIERE

MACHINE DE TERRASSEMENT

Tarières hydrauliques pour pelle de 1,5 à 8,0 tonnes

Équipement adapté à la création de forages à la fois sur le sol et sur la roche grâce aux deux types de vrille disponibles.

Possibilité à l'utiliser sur les pelles et les chargeuses compactes (en utilisant l'adaptateur approprié)

Support d'articulation pour faire des forages perpendiculaires dans chaque inclinaison de pente.

Capacité de forer horizontalement



Pelle	T	1,5-1,8	1,8-4,0	4,0-8,0
Modèle		T15	T20	T50 T50
A	Mm	475	600	720
B	Mm	250	300	300
Couple De Travail	n/m	1500	2500	5000
Poids	Kg	80	135	172
Consom d'huile	lt/min	20/40	30/60	45/80
Pression Travail	Bar	160	180	200
Déplacement	Cc	125	200	250

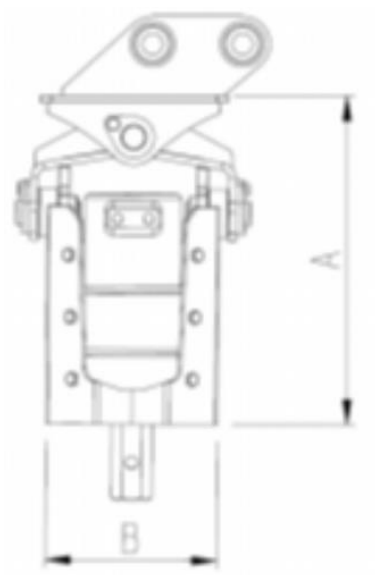

VRILLE ET ACCESSOIRES



VRILLE POUR LA ROCHE



VRILLE STANDARD

Pointe standard hexagonale standard 50 longueur 1000mm		Pointe pour la roche Hexagone 50 longueur 1000mm		Rallonge	
PS100 (PS100)	Ø 100	PR100	Ø 100	PRLTE100	Ø 100
PS150	Ø 150	PR150	Ø 150	PRLTE150	Ø 150
PS200 (en)	Ø 200	PR200	Ø 200	PRLTE200	Ø 200
PS250	Ø 250	PR250	Ø 250	PRLTE250	Ø 250
PS300	Ø 300	PR300	Ø 300	PRLTE300	Ø 300
PS350	Ø 350	PR350	Ø 350	PRLTE350	Ø 350
PS400	Ø 400	PR400	Ø 400	PRLTE400	Ø 400
PS500 (en)	Ø 500 pas T15	PR500	Ø 500 pas T15	PRLTE500	Ø 500 pas T15

Tip	Extension 1000mm
Admt 	Adaptateur pour Mini-pelle
Pc	Pointe conique pour scie à bois

GODET MALAXEUR

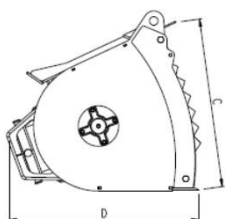
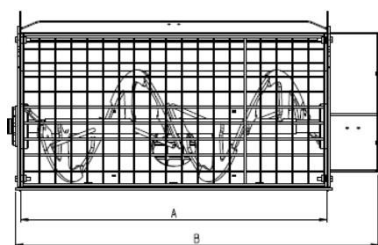

Modèle		BM150	BM200	BM250	BM350	BM450
A	Mm	1000	1250	1250	1350	1650
B	Mm	1260	1490	1490	1590	1890
C	Mm	560	560	620	730	730
D	Mm	630	630	730	840	840
Poids	Kg	200	310	350	450	510
POIDS TOTAL	Kg	500	780	930	1250	1500
POIDS MAXIMUM DE CHARGE	Litre s	150	200	250	350	450
PRESSION MAX	Bar	140	140	140	140	140
Transmission	Typ e	Réducteur	Réducteur	Réducteur	Réducteur	Réducteur
ATTACHE STANDARD 2 AXES POUR PELLE (6-10 tonnes) - MOD. ATS (BM 6-10)						
ATTACHE STANDARD 2 AXES POUR PELLE (10-20 tonnes) - MOD. ATS (BM 10-20)						

COMPLET AVEC :

- Ouverture de l'évent hydraulique
- Grille De protection fixe
- Moteur hydraulique avec réducteur à engrenages
- Construction anti-usure Hardox

GODET ORIENTABLE

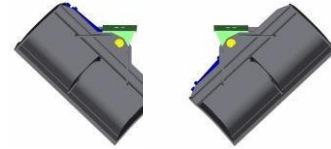
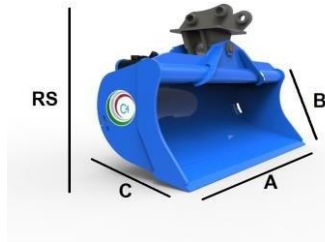

Large orientation : jusqu'à 45 degrés par côté

**Gamme complète pour les pelles
de 1,2 à 8,0 tonnes.**

Modèle	A	B	RS mm	Bar P. Max	Kg	C.SAE
POUR LES PELLES DE 1,2 À 1,8 TONNE.						
<i>Bo35-800</i>	<i>800</i>	350	520	150	75	70
<i>Bo35-1000</i>	<i>1000</i>	350	520	150	84	89
<i>Bo35-1200</i>	<i>1200</i>	350	520	150	94	109
POUR LES PELLES DE 1,8 À 2,8 TONNES.						
<i>Bo37-1050</i>	<i>1050</i>	370	615	250	143	118
<i>Bo37-1200</i>	<i>1200</i>	370	615	250	152	137
<i>Bo37-1400</i>	<i>1400</i>	370	615	250	166	161
POUR LES PELLES DE 3,0 À 3,5TONNES.						
<i>Bo42-1050</i>	<i>1050</i>	420	660	250	152	148
<i>Bo42-1200</i>	<i>1200</i>	420	660	250	163	172
<i>Bo42-1300</i>	<i>1300</i>	420	660	250	184	187
<i>Bo42-1400</i>	<i>1400</i>	420	660	250	177	203
POUR LES PELLES DE 3,5 À 5,0 TONNES.						
<i>Bo46-1200</i>	<i>1200</i>	460	700	250	186	195
<i>Bo46-1300</i>	<i>1300</i>	460	700	250	194	220
<i>Bo46-1400</i>	<i>1400</i>	460	700	250	202	231
<i>Bo46-1500</i>	<i>1500</i>	460	700	250	210	246
<i>Bo46-1600</i>	<i>1600</i>	460	700	250	210	248
POUR LES PELLES DE 5,0 À 8,0 TONNES.						
<i>Bo52-1250</i>	<i>1250</i>	520	795	300	275	260
<i>Bo52-1400</i>	<i>1400</i>	520	795	300	391	295
<i>Bo52-1500</i>	<i>1500</i>	520	795	300	300	318
<i>Bo52-1600</i>	<i>1600</i>	520	795	300	311	341
<i>Bo52-1700</i>	<i>1700</i>	520	795	300	349	350
<i>Bo52-1800</i>	<i>1800</i>	520	795	300	357	357

GRAPPIN

Accessoires adaptés à la manutention du fer et aux matériaux en vrac tels que la ferraille, les déchets industriels et urbains, le plastique, papier etc...

Le corps et les cylindres sont construits avec du matériel de haute qualité, des pelles et des dents avec de l'acier anti-usure.

GRAPPIN A FERAILLE/MATÉRIAUX EN VRAC

CARACTERISTIQUES : Bagues et goupilles construites avec des aciers spéciaux et un traitement de durcissement pour assurer une longue durée de vie ; flexibles interchangeable ; tête couverte par un carter entièrement démontable.

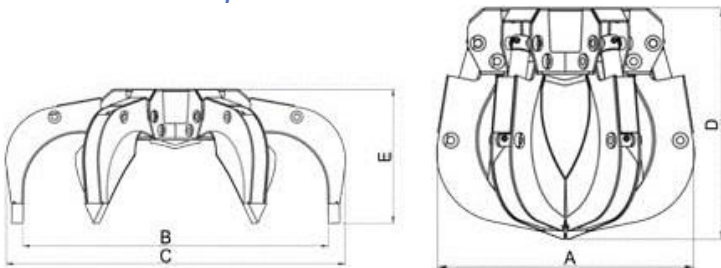

Modèle	DENTS NON.	CAPACITÉ (LT)	POIDS (KG)	PRESS MAX (BAR)	GAMME DE PÉTROLE E (LT/MIN)	A (mm)	B (mm)	C (mm)	D (mm)	Et (mm)	TON
PFR 100/4	4	100	100	200	40	680	990	1120	590	485	1,5 - 3,0
PFR 130/4	4	130	115	250	40	800	1170	1340	710	550	1,8 - 3,0
PFR 130/5	5	130	130	250	40	800	1170	1340	710	550	1,8 - 3,0
PFR 180/4	4	180	235	300	60	925	1400	1510	800	650	5
PFR 210/5	5	210	275	300	60	925	1400	1510	80	650	5
PFR 270/4	4	270	310	300	60	900	1560	1720	900	680	7
PFR 270/5	5	270	345	300	60	900	1560	1720	900	680	7
PFR 270/6	6	270	385	300	60	900	1560	1720	900	680	7
PFR 320/4	4	320	385	300	60	1065	1690	1850	920	700	9,0 - 10,0
PFR 320/5	5	320	405	300	60	1065	1690	1850	920	700	9,0 - 10,0
PFR 320/6	6	320	485	300	60	1065	1690	1850	920	700	9,0 - 10,0
PFR 400/4	4	400	490	300	60	1090	1900	2050	1020	730	9,0 - 10,0
PFR 400/5	5	400	525	300	60	1090	1900	2050	1020	730	10
PFR 400/6	6	400	595	300	60	1090	1900	2050	1020	730	10

Accessoires : Machine et rotateur attache (voir Section Accessoires)

GRAPPIN A FERAILLE - SÉRIE LOURDE

CARACTERISTIQUES : rotor encastré ; carter de couvert ; possibilité de pale sur mesure.

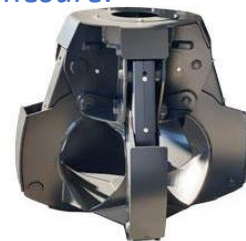
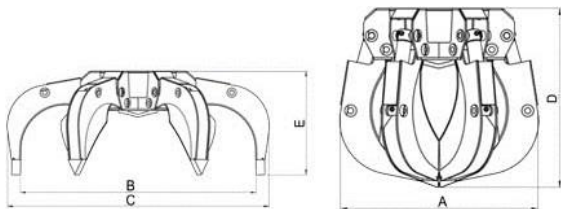

Modèle	DENTS NO N.	CAPACITÉ (LT)	POIDS (KG)	PRESS MAX (BAR)	GAMME DE PÉTRO LE (LT/MIN)	Un (mm)	B (mm)	C (mm)	D (mm)	Et (mm)	TON
PFRP 350/5	5	350	850	250	90	1350	1760	1980	1140	890	1,0 - 1,4
PFRP 450/5	5	450	950	250	90	1380	1850	2080	1200	900	1,5 - 2,0

Accessoires : Machine et rotateur attache (voir Section Accessoires)

GRAPPIN POUR MATÉRIAUX DIVERS

CARACTERISTIQUES : Cinq griffes encadrées de vérins indépendants qui permettent de se déplacer facilement avec du matériau même en vrac de divers types ; Pas de tuyau hydraulique visible ; Douilles auto-lubrifiantes ; Axes chromés ; Coussins en hardox antiusure

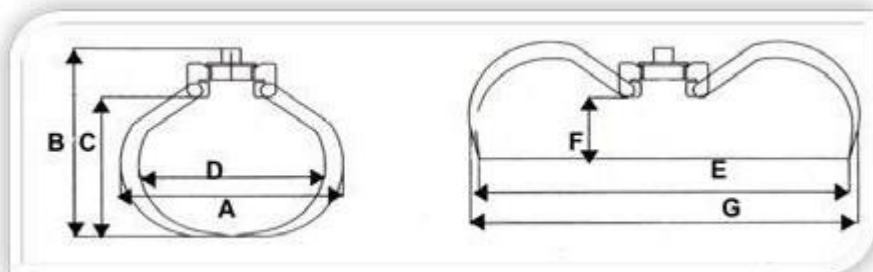

Modèle	CAPACITÉ (LT)	POIDS (KG)	A (mm)	B (mm)	D (mm)	E (mm)	F (mm)	TON
PR120	120	135	870	890	650	1200	350	1,8 - 3,0
PR160	280	200	980	935	800	1600	180	3,0 - 8,0
PR190	380	270	1280	1155	980	1950	250	6,0 - 10,0
PR220	540	320	1510	1175	1170	2125	350	8,0 - 15,0

Accessoires : Machine et rotateur attache (voir Section Accessoires)

Pinces

Les pinces C4 sont idéales pour la manutention des troncs, du bois et des branches.

Ils sont construits avec des matériaux de haute qualité et de résistance, assurant ainsi la durabilité à long terme.

La rotation hydraulique à 360 degrés facilite le déplacement du matériau, ce qui rend l'utilisation optimale.

Des pinces C4 peuvent être installées sur les pelles de 1,5 à 17 tonnes.

PINCE A BOIS

CARACTERISTIQUES : Lames en acier à haute résistance pour assurer une capacité de charge maximale ; bagues auto-lubrifiées + clapet de sécurité, axes chromés pour la fluidité et la durabilité.

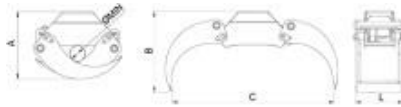



Modèle	PL100 (PL100)	PL110	PL130	PI150	PL150L	PL175	PL175L
Poids (kg)	60	80	130	220	160	300	260
Capacité (kg)	1000	1900	2200	3500	3500	3800	3800
île min (mm)	70	70	100	100	100	130	130
A (mm)	385	420	499	630	630	700	700
B (mm)	510	560	660	818	818	880	880
C (mm)	1000	1100	1400	1600	1600	1800	1800
L (mm)	315	340	410	570	410	645	490
(T)	1,5 - 2,0	2,0 - 3,5	3,0 - 5,0	6,0 - 10,0	6,0 - 10,0	10,0 - 17,0	10,0 - 17,0

Accessoires : Machine et rotateur attache (voir Section Accessoires)

PINCE À BOIS

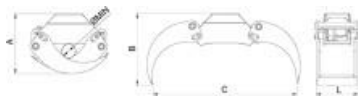
CARACTERISTIQUES : Grappin renforcé ; Idéal pour le chargement de broyeur.



Modèle	PLA110	PLA130	PLA150	PLA150L	PLA175	PLA175L
Poids (kg)	100	150	250	190	320	300
Capacité (kg)	1900	2200	3500	3500	3800	3800
île min (mm)	70	100	100	100	130	130
A (mm)	420	499	630	630	700	700
B (mm)	560	660	818	818	880	880
C (mm)	1100	1400	1600	1600	1800	1800
L (mm)	460	520	670	520	740	600
 (ton)	2,0 - 3,5	3,0 - 5,0	6,0 - 10,0	6,0 - 10,0	10,0 - 17,0	10,0 - 17,0

Accessoires : Machine et rotateur attache (voir Section Accessoires)

PINCE A BOIS RENFORCÉE

CARACTERISTIQUES : Grappin renforcé

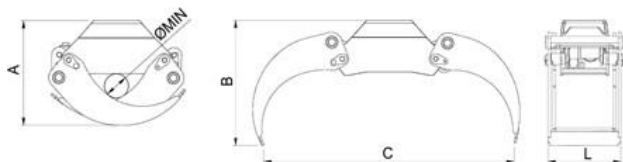

Modèle	PLR110	PLR130	PLR150	PLR150L	PLR175	PLR175L
Poids (kg)	115	155	270	200	340	315
Capacité (kg)	1900	2200	3500	3500	3800	3800
île min (mm)	70	100	100	100	130	130
A (mm)	420	499	630	630	700	700
B (mm)	560	660	818	818	880	880
C (mm)	1100	1400	1600	1600	1800	1800
L (mm)	460	520	670	520	740	600
(ton)	2,0 - 3,5	3,0 - 5,0	6,0 - 10,0	6,0 - 10,0	10,0 - 17,0	10,0 - 17,0

Accessoires : Machine et rotateur attache (voir Section Accessoires)

PINCE à BOIS RENFORCÉE HD

CARACTERISTIQUES : Grappin renforcé ; bague anti-usure cimenté ; Piston renforcé pour la haute pression ; Tonnage adapté au travail lourd (800 barres)

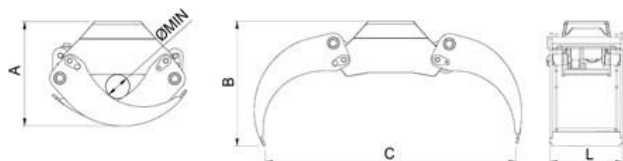

Modèle	PL130HD PL130HD	PL150HD PL150HD	PL150LHD PL150LHD	PL175HD PL175HD	PL175LHD PL175LHD
Poids (kg)	155	270	200	340	315
Sur	2200	3500	3500	3800	3800
île	100	100	100	130	130
A (mm)	499	630	630	700	700
B (mm)	660	818	818	880	880
C (mm)	1400	1600	1600	1800	1800
L (mm)	520	670	520	740	600
(ton)	3,0 - 5,0	6,0 - 10,0	6,0 - 10,0	10,0 - 17,0	10,0 - 17,0

Accessoires : Machine et rotateur attache (voir Section Accessoires)

ACCESSOIRES

POUR LES GRAPPIN ET LES PINCES

ROTATEURS

CARACTERISTIQUE : En fonte ; arbre construit en acier avec une dureté de surface très élevée, Arbre réalisé en acier à élasticité élevée

Série avec GOUJON

Code	Type	Poids (kg)	Charge max en fixe (kg)	Charge max en dynamique (kg)	Couple (Nm)	Consommation d'huile (lt/min)	Pression MAX en travail (bar)	(ton)
R01 (R01)	4 vie	10	1000	500	450	10	250	0,0 - 2,0
R03 (R03)	4 vie	16.5	3000	1500	1000	20	250	2,0 - 4,0
R05 R05	4 vie	21	5000	2500	1300	20	250	5,0 - 6,0
R06 R06	4 vie	29.5	6000	3000	1500	25	250	6,0 - 8,0
R10	4 vie	59	10000	5000	2500	30	250	8,0 - 13,0
R12	4 vie	70	12000	6000	2900	35	250	13,0 - 17,0
R16	4 vie	71	16000	8000	3400	40	250	13,0 - 17,0
RM7 (en)	6 vie	57	7000	3000	1850	25	250	3,0 - 8,0
RM10	6 vie	64	10000	5000	2500	30	250	8,0 - 13,0
RM12	6 vie	77	12000	6000	2900	35	250	13,0 - 17,0
RM16	6 vie	79	16000	8000	3400	40	250	13,0 - 17,0



Série avec BRIDE

Code	Type	Poids (kg)	Carico max statico (kg)	Carico max dinamico (kg)	Couple (Nm)	Flux d'huile (lt/min)	Lavoro presse Max (bar)	(ton)
RA03-F	4 vie	21.5	3000	1500	1000	20	250	2,0 - 4,0
RA05-F	4 vie	26	5000	2500	1300	20	250	5,0 - 6,0
RF07-F	4 vie	44	7000	3500	1800	25	250	6,0 - 8,0



LES ATTACHES

ATTACHE 1 AXE		ATTACHE SUR 2 AXES (ATTACHE RAPIDE)		CONNEXION DOUBLE PIVOT SANS ROTOR	
AT01	ROTATORE R01	ATR01 (EN)	ROTATORE R01- R03-R05-R06	ATD01 (EN)	Excavatrice 1.5-5.0 tonnes
AT02	ROTATORE R03- 05	ATR02 (EN)	ROTATORE R07- RM7-R10 - RM10	ATD02 (EN)	Excavatrice 5.0 - 10.0 tonnes
AT03	ROTATORE R06- R10 -RM7- RM10	ATR03 (ATR03)	ROTATORE R12- R16-RM12-RM16	ATD03 (EN)	Excavatrice 12.0 - 17.0 tonnes
AT04	ROTATORE R12- R16 - RM12- RM16				

IMPORTATEUR EN FRANCE
METROPOLITAINE, DOM-TOM, SUISSE
ET BELGIQUE

CHAMBAT
Mécanique

FLEXIBLES
VERINS
SOUDURES
PIÈCES

VENTE ET REPARATION DE MACHINES ET EQUIPEMENTS MECANIKUES
04.50.26.64.09

306 ROUTE DE L'USINE 74140 SCIEZ-SUR-LEMAN

WWW.CHAMBATMECANIQUE.FR

CHAMBAT.MECANIQUE@GMAIL.COM

04.50.26.64.09



C4 MECCANICA S.R.L.

Zone Ind.le Madonna del Moro - 06019 Umbertide (PG)

www.c4meccanica.it

C4 Mécanique

Tél. 075 941 59 98 - 327 533 50 88 - Fax 075 94